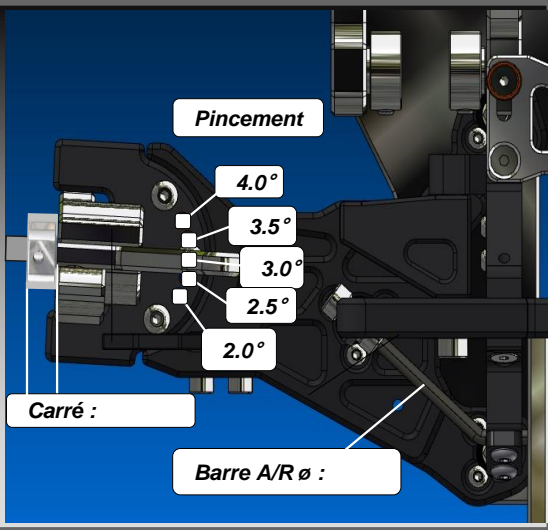
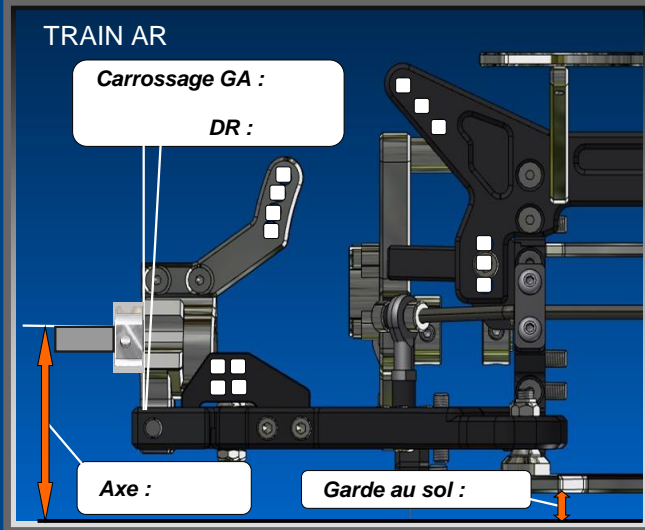
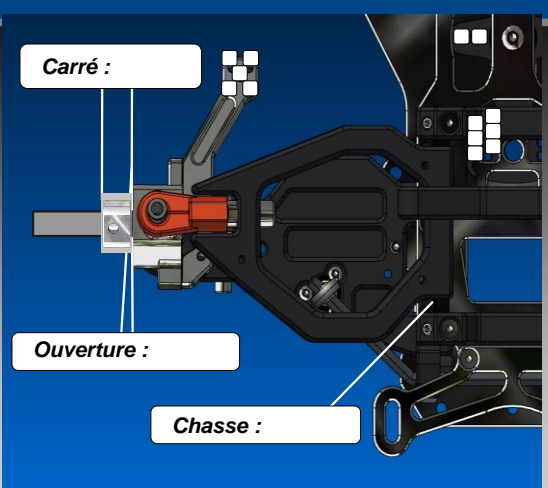
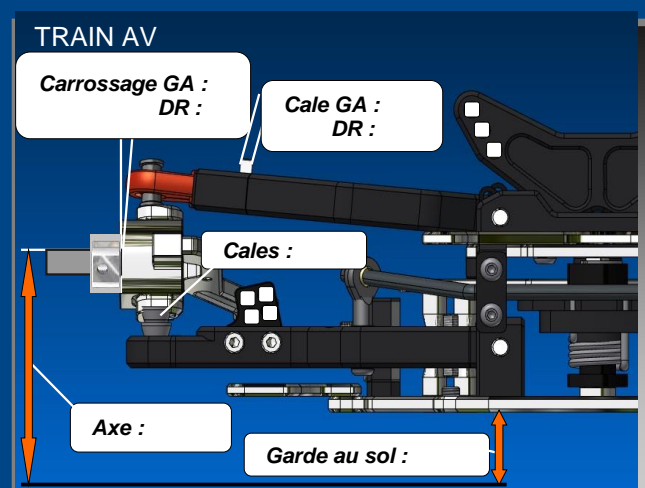
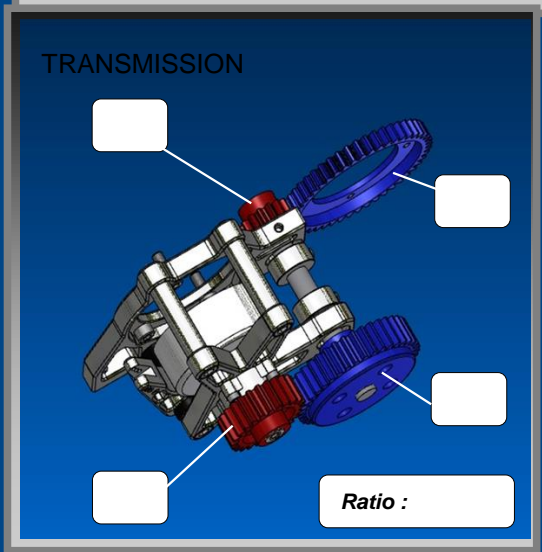

Date : _____
 Événement : _____
 Pilote : _____

Moteur : _____
 Embayage : _____
 Échappement : _____
 Différentiel : _____
 Carrosserie : _____

Piste : _____
 Aspect : _____
 Grip : _____
 Conditions : _____
 T° Air : _____
 T° Piste : _____
 Pneus AV-GA: DR: _____
 Pneus AR-GA: DR: _____

RATIOS

48	15	41	23	5,70
48	15	40	23	5,57
48	15	41	24	5,47
48	15	39	23	5,43
48	16	41	23	5,35
48	15	40	24	5,33
48	15	41	25	5,25
48	16	40	23	5,22
48	15	39	24	5,20
48	16	41	24	5,13
48	15	40	25	5,12
48	16	39	23	5,09
48	16	40	24	5,00

- ### Ressorts AR
- JAUNE - ø2.5 / 8
 - GRIS - ø2.6 / 8
 - VERT F - ø2.65 / 8
 - NOIR - ø2.7 / 9
 - BLEU - ø2.7 / 8.5
 - VERT - ø2.7 / 8
 - + ORANGE - ø2.75 / 8
- ### Ressorts AV
- OR - ø2.8 / 8
 - ROUGE - ø2.9 / 8
 - BLANC - ø3.0 / 8
 - + ROSE - ø3.2 / 8

NOTES
